



Peninsula Ukulele Group

Community • Learning • Making Music

# Uke University

A one month weekly lesson series for beginner - FREE

Have you ever wanted to play ukulele? Got a new ukulele and don't know where to start? Would you like to meet new friends from the ever growing ukulele community?



Our classes are geared for a new beginner with 4 weekly 90 minute free classes. You will learn everything from how to tune your uke, strum, play chords and will play your first song at the end of lesson one! Fast paced, hands on and fun with ukulele instructors available to assist you. All ages are welcome.

You will end the series playing in your first Jam Session with the PUGs accompanied by an instructor. No worries! So bring your ukulele or check one out at any San Mateo Library for free. Join the fun and sign up now!



**Wednesdays 6-7:30pm**

**Sept 6**

**Sept 13**

**Sept 27**

**Belmont Library**

[www.peninsulaukulelegroup.com](http://www.peninsulaukulelegroup.com)

## **Week One**

Welcome to the Ukulele Community!

Introductions

Name/how long playing

Orientation: Uke parts

How to tune: tuners, standard vs linear, high/low G

How to strum: downstrum, DUDU

Learn 1 finger chords, C C7 Am A7

Play 1 chord song- Row, Row, Row Your Boat

Learn 2 finger chords- F D7 A

Learn Swing Strum- D DU D DU

Play- Mary Had A Little Lamb

Homework: watch Uke Minutes episode #100

Practice all chords and

Chord transitions: C-Am, F-Am, C-A7, F/C, D7/F/C

Watch Cynthia Lin/Swing Strum/Don't Worry Be Happy

Practice Don't Worry Be Happy

# Your first ukulele lesson

## Step 1. Get to know your uke

On the diagram to the right, find the **strings**, **frets**, and **tuners**.

Locate each of these on your ukulele. We'll use all of those today!

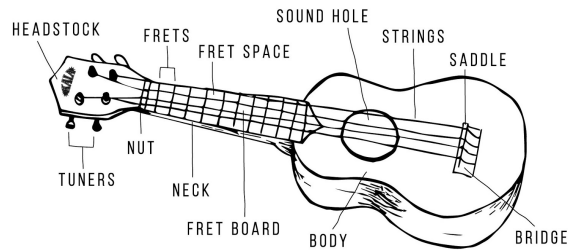

## Step 2. Tuning your ukulele

The ukulele has four strings, tuned to G, C, E, A, in one of two ways:

### High G, reentrant

- The classic Hawaiian sound. On the right.

### Low G

- A fuller, but less traditional, sound.

Easiest tuner app: The *Kala Tuner*, available on iOS & Android. This tuner shows you exactly what knob to turn, making it perfect when you are getting started and your uke is very out of tune.

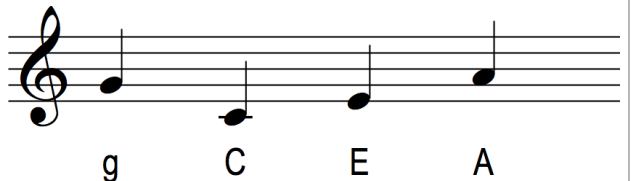
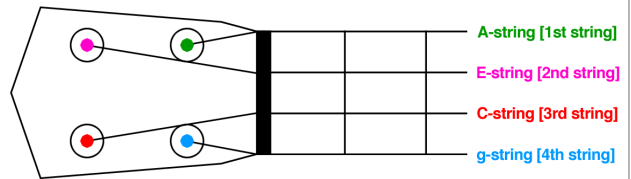

## Step 3. Your first chords - C, G, Am, F

Learn                      Play a chord progression

C	C
Am	C, Am
F	C, Am, F
G	C, G, Am, F

We will play each of these, four strums per chord.

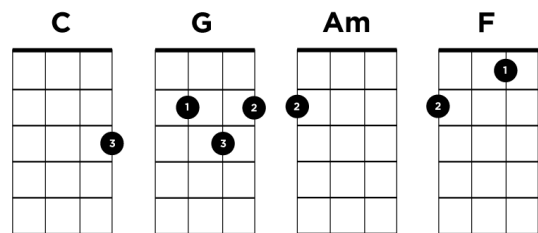

## Step 4. Your first song

Congratulations, you've learned your first four chords! This exact chord progression (C, G, Am, F) appears in many songs, including those on the right.

*I'm Yours* - Jason Mraz  
*You Belong With Me* - Taylor Swift  
*Hey Soul Sister* - Train  
*Don't Stop Believing* - Journey  
*Can You Feel the Love Tonight* - Elton John  
*With Or Without You* - U2  
*Take On Me* - a-ha  
*It's My Life* - Bon Jovi  
*Someone Like You* - Adele

# Learning 1 finger chords

## C C7 Am A7

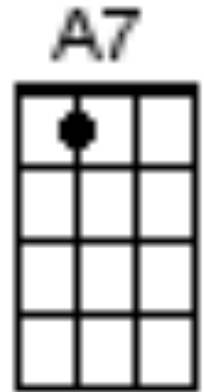
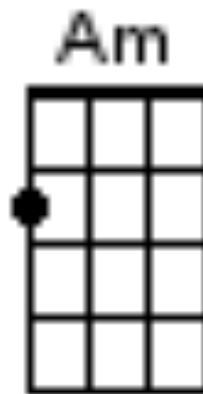
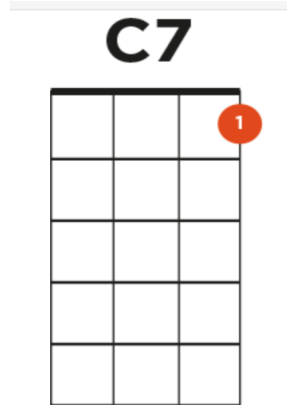
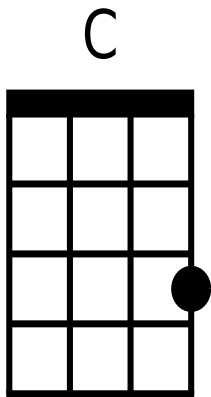

# 2 finger chords

## F D7 A

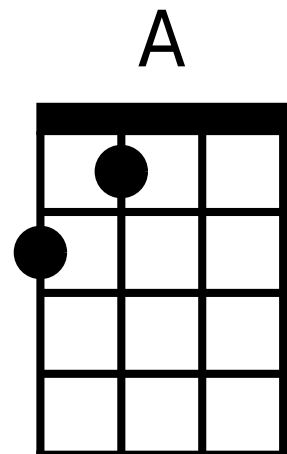
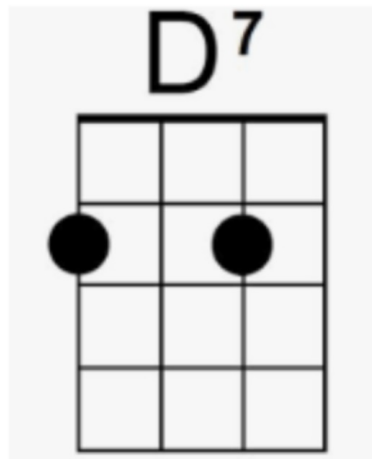
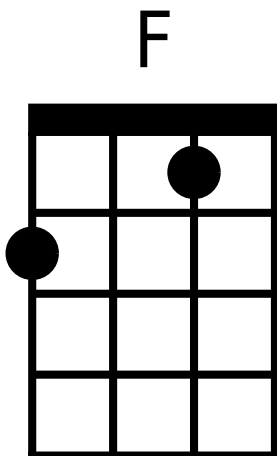

# Row, Row, Row Your Boat

---

Level 1

VMM

## Ukulele Play-Along:

Row, Row,  
Row Your Boat



Featuring:

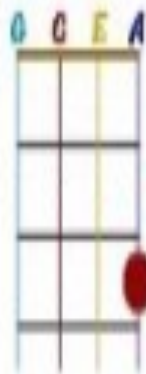

*C Major*

Don't Worry Be Happy (C/Dm/F)  
Review of Swing Strum, 3:04



**Play 2 Chord Song- F C7**  
**Mary Had A Little Lamb**  
**Bernadette Plays Music 2:49**



# Reading a chord chart

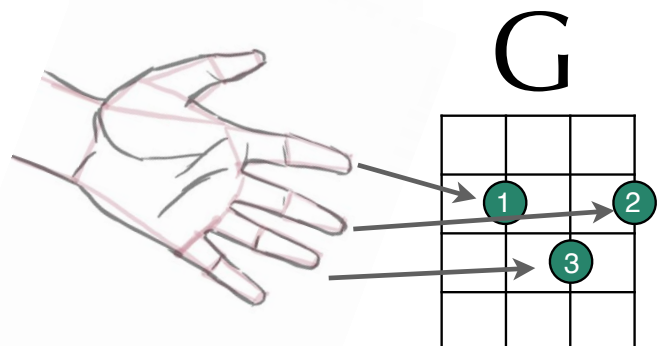
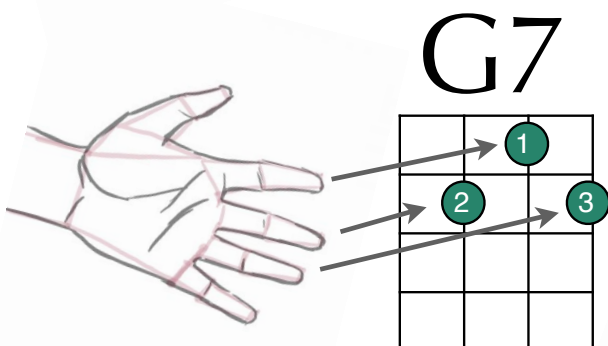
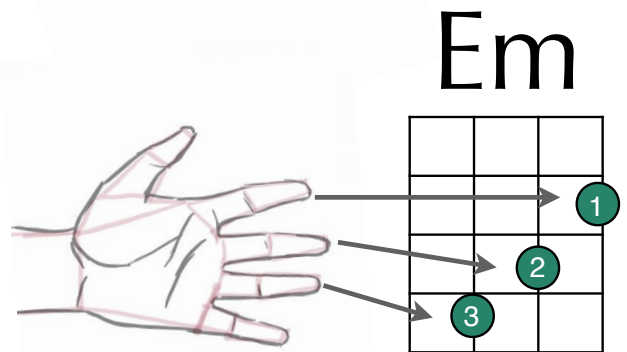
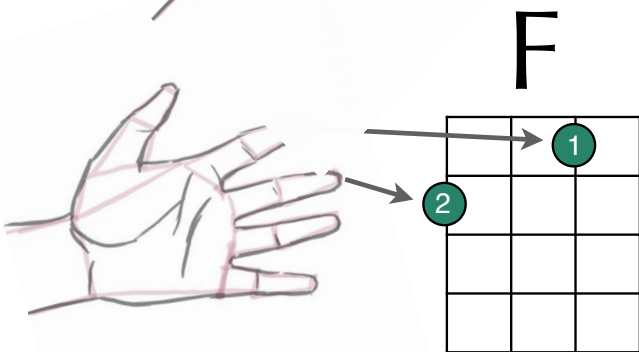
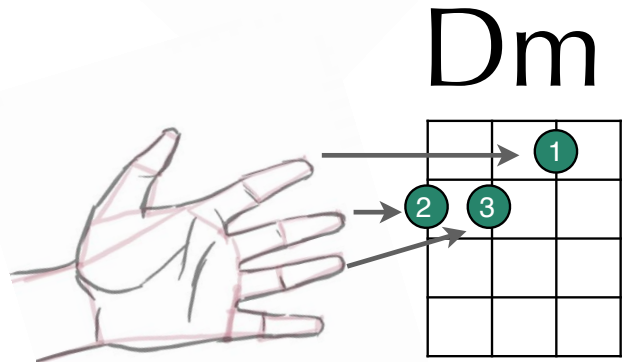
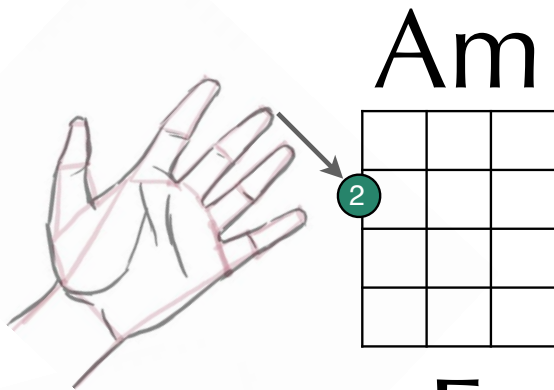
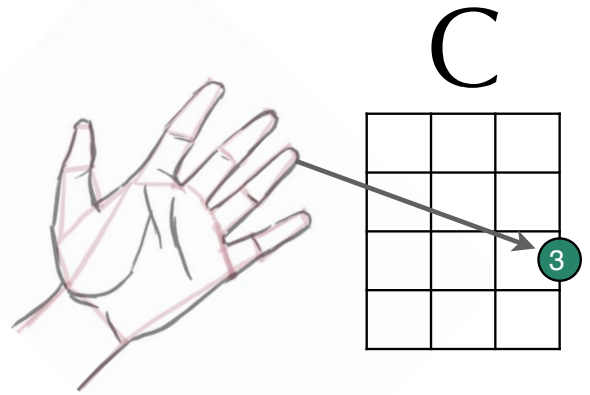
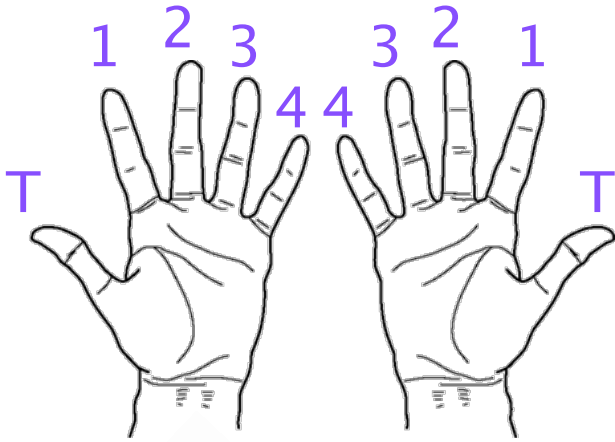



# UKULELE CHORDS

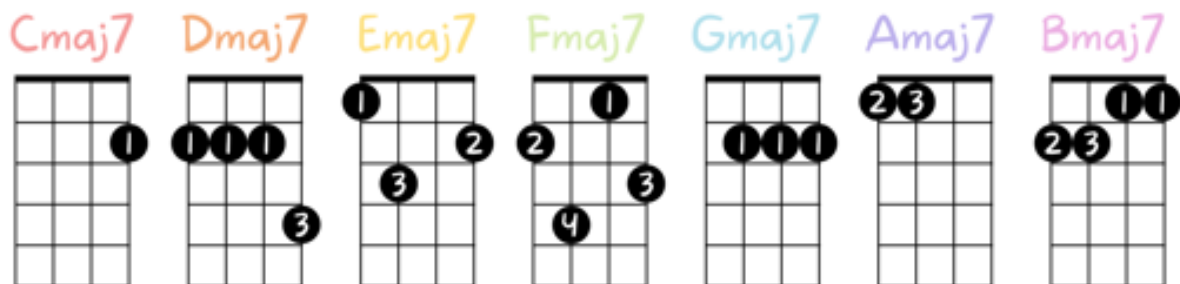
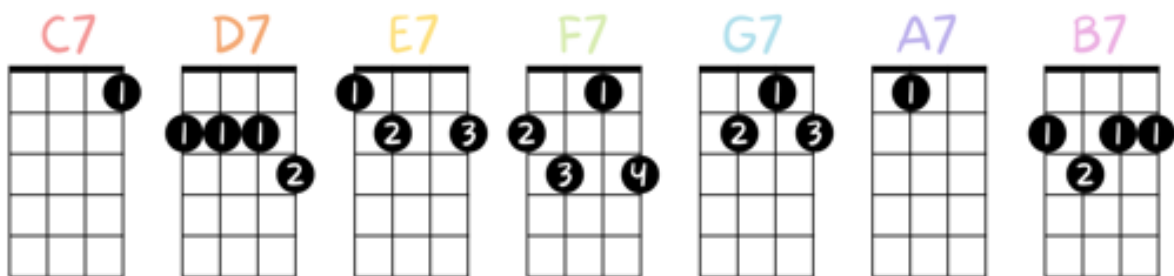
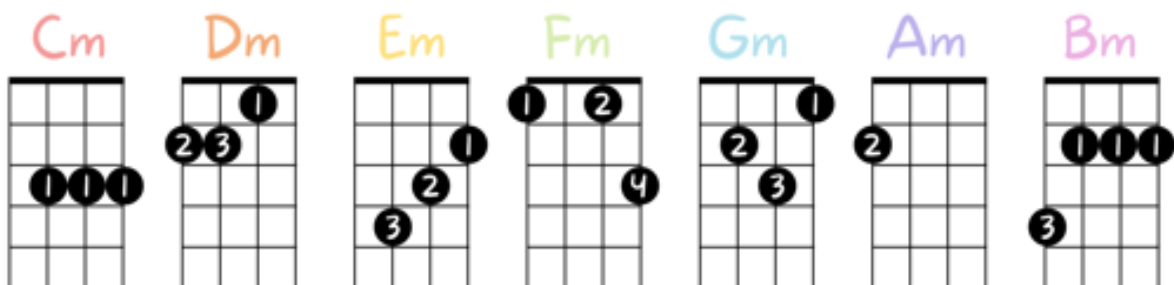
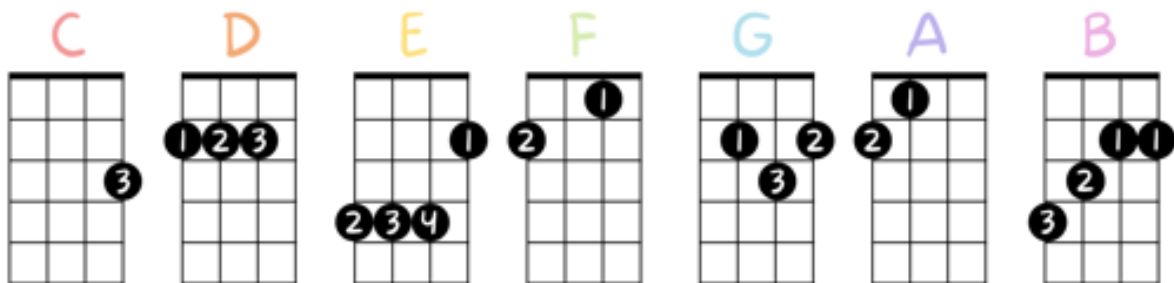

## **Week Two**

### **Review homework-**

Learnings and Questions?

Quiz on uke parts

Play- Don't Worry Be Happy

Learn 3 finger chords- G G7 D Dm Em E7

Learn 4 finger & diminished chords- Bb, B7, Cdim7

Learn barre chords- D6=2222

Learn Island Strum- D DU UDU

Watch/Play- Cynthia Lin/Stand By Me

Play 3 chord song-

Happy Birthday

Homework- Watch "Playing and strumming at same time" and

"Island Strum/Stand By Me"

Cynthia Lin/YouTube

Practice chords, Chord transitions and Island strum

Practice songs- Happy Birthday,

Stand By Me

Don't Worry Be Happy (C/Dm/F)  
Review of Swing Strum, 3:04



## Learning 3 finger chords

D Dm Em E7

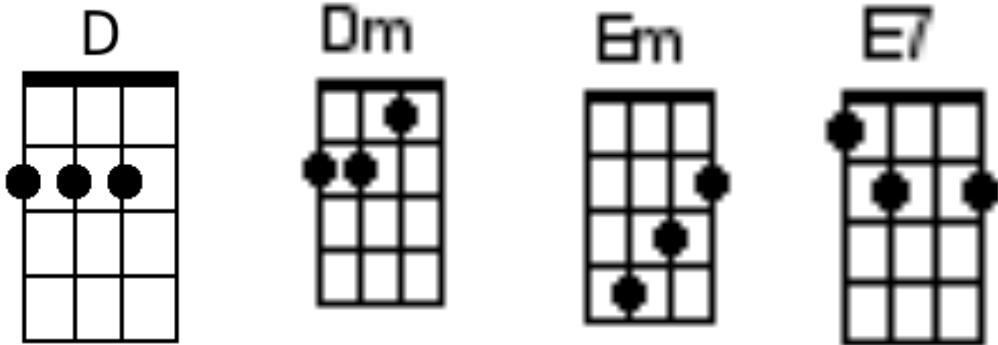

## Learning 4 finger chords

Bb B7, D6 (barre chord)

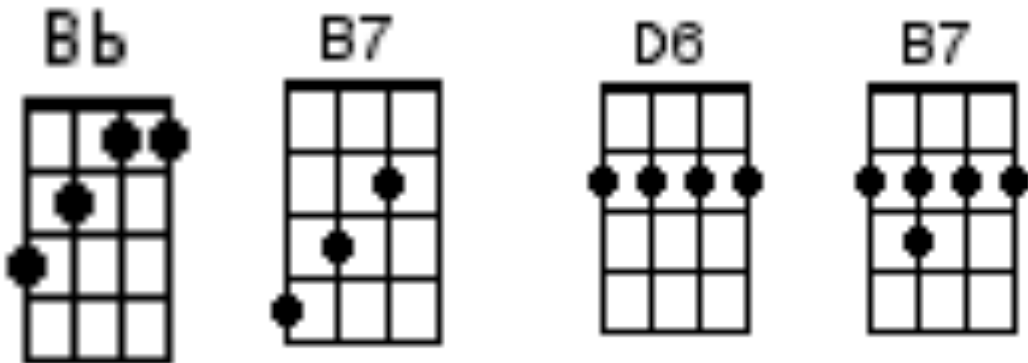

## Learning Diminished chords

Cdim- 2323, zigzag shape

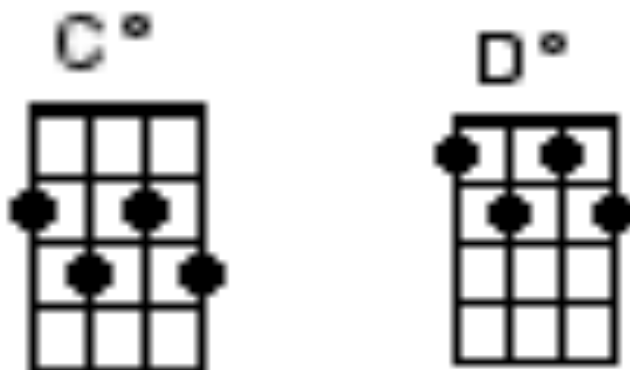

# Learn Island Strum D DU UDU Stand By Me/Cynthia Lin- 2:35

**Island Strum  
tutorial**

**3 Million views**

**Beginner Uke  
Lesson #4:  
Stand by Me**

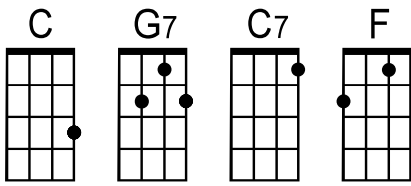

# Happy Birthday

Key of C: 

C
G7
C
F  
 Happy Birthday to you, happy birthday to you,  
C7
F
C
G7
C ~~~  
 Happy Birthday dear-----, Happy Birthday to you!

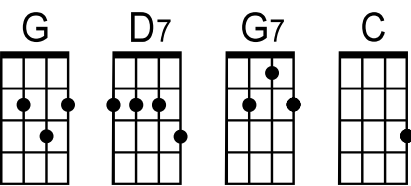
Key of G: 

G
D7
G
C  
 Happy Birthday to you, happy birthday to you,  
G7
C
G
D7
G ~~~  
 Happy Birthday dear-----, Happy Birthday to you!

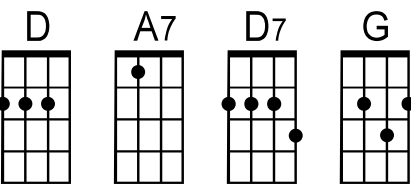
Key of D: 

D
A7
D
G  
 Happy Birthday to you, happy birthday to you,  
D7
G
D
A7
D ~~~  
 Happy Birthday dear-----, Happy Birthday to you!

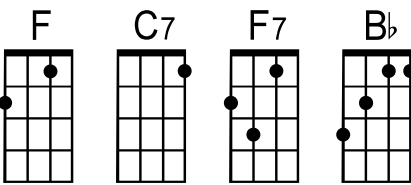
Key of F: 

F
C7
F
Bb  
 Happy Birthday to you, happy birthday to you,  
F7
Bb
F
C7
F ~~~  
 Happy Birthday dear-----, Happy Birthday to you!

## **Week Three- You Made It!**

Any questions?

### **Learn Movable chords**

Aldrine Guerrero/Movable Chords video

Review Chromatic Scale/Uke Fretboard

A/F/C/Am/C7 movable chord shapes

### **Reading Uke Tablature-**

Watch Cynthia Lin/Intro to Tabs/Happy Birthday

### **Preparing for Jam Sessions**

Review/practice the songs in advance

How to find playlist/PUGs website

[www.peninsulaukulelegroup.com](http://www.peninsulaukulelegroup.com)

### **Survival tips- You can do it!**

Play the root chord if you are unfamiliar with chord,

Dsus2-D, Fm7-F, Gaug-G

E-E7 or barre 4th fret

Or play “Chord Zed” (mute all strings)

Stay in tempo, skip chord changes, don't be a hero

**2024- Uke University- Intermediate preview**

**Graduation Ceremony**

Homework- practice! 5-30 mins daily

Review Beginner Resource Resource List

Attend your first Meetup and have fun!

# Chromatic Scale/Uke Fretboard Diagram

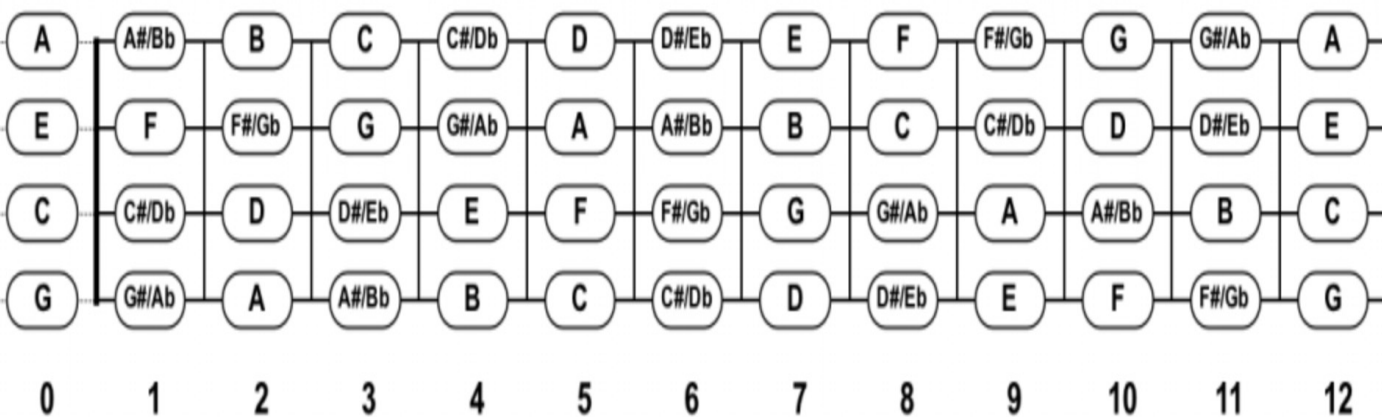

[Home](#) > [Lessons and Advice](#)





**Movable Chords video**  
**Aldrine Guerrero**  
**Ukulele Underground**  
**Uke Minutes 17**



# Beginner Lesson • Reading Tablature

REV: January 2016

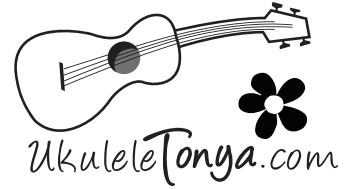

Sometimes ukulele songs (and those of other stringed instruments) are shown in tablature. In ukulele tablature, the four lines each represent one of the ukulele's strings; I've included the string names to the left of the line to show you. Note that the "bottom" line, is the "G" string.

For many folks, tablature at first seems a bit "backwards" in where you'd guess the notes to be. It sometimes helps to think of holding up your ukulele to the tablature and you can "see" where the strings/notes are in relation to the lines.

The numbers on the line tell you which fret you need to press that string down. If there's a "0" it means you should pluck it as an open string (no fingers on any of the frets).

If you don't know how to read standard musical notation but you do learn to read tablature, you can quickly "teach" yourself to read simple musical notation by comparing the fingers you're using in the tablature to the note depicted directly above it in the standard notation. Then all you have to do is memorize the "letter name" of the fingers you're playing and you'll also learn to read the treble clef (no bass clef for ukulele--our instruments don't go that low).

Knowing how to read tablature allows you to venture into melody, not simply chords. You can also learn to play "chord-melody" style which blends playing melody with strumming chords; it's pretty impressive and not as difficult as it sounds.

When you see an "X" on one (or more) of the lines, or when you see nothing at all on it, that means not to play that string at all. This is very different than having a "0" on a string—which means that you play that string but you play it "open" (with no finger on the string).

A			3	3		5	5	3
E	1	1						
C								
G								

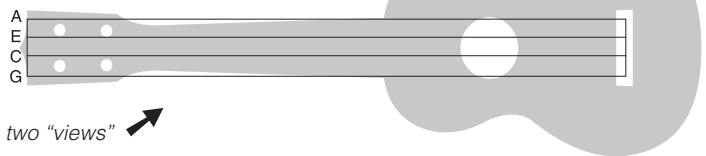

← Compare the two "views" →

**Try it for yourself; pluck each note shown once. Do you recognize the song?**

A			3	3		5	5	3		1	1	0	0		
E	1	1											3	3	1
C															
G															

Here's how to "translate" it:

*Measure 1: For the first two notes, hold down the second string (E string) at the first fret. For the second two notes, hold down the first string (A string) at the third fret.*

*Measure 2: For the first two notes, hold down the first string (A string) at the fifth fret. The third and final note in the measure is on the first string, third fret.*

*Measure 3: For this measure, you're playing entirely on the first string (A string). The first two notes are on the first fret; the second two notes are "open" (no fingers) on that string.*

*Measure 4: This measure is played entirely on the second (E) string. The first two notes are on the third fret; the last note is on the first fret.*

**Cynthia Lin- Intro to Reading Tabs, to 4:00  
Fingerpicking Happy Birthday, 14:20**



# HAPPY BIRTHDAY - Intro to Tab

traditional

Ukulele arrangement by Cynthia Lin, <http://cynthialin.com/ukulele>

how to read tab:

- the 4 lines represent your 4 strings with the string names at the left.
- the numbers tell you what fret you are pressing on the given string. 0 means open string
- in your left hand, press the fret down. use any finger for now.
- in the right hand, pluck the string that the number is on. you can use your thumb for now.

```
1st  A |-----|
     E |-----1--0--|
     C |--0--0--2--0--|
     G |-----|
```

Hap-py Birth-day to You

```
2nd  A |-----|
     E |-----3--1--|
     C |--0--0--2--0--|
     G |-----|
```

Hap-py Birth-day to You

```
3rd  A |-----3--0-----|
     E |-----1--0-----|
     C |--0--0-----2--|
     G |-----|
```

Hap-py Birth-day dear Chew-ie

```
4th  A |--1--1--0-----|
     E |-----1--3--1--|
     C |-----|
     G |-----|
```

Hap-py Birth-day to You

Larry Shaw,  
Organizer  
Co-Organizers:  
Linda Cook  
Glenn Lew  
Astrid Jacob



**Peninsula Ukulele Group**

Connect • Learn • Have Fun

[www.meetup.com/Peninsula-Ukulele-Group](http://www.meetup.com/Peninsula-Ukulele-Group)

Meetups at  
Belmont  
Library  
3<sup>rd</sup> Wed, 6-8pm

# Beginners Ukulele Lesson/Resource Packet

## Learn to Play:

Ukulele Underground  
Uke Minutes #100/Youtube  
[www.ukuleleunderground.com](http://www.ukuleleunderground.com)

The Ukulele Teacher  
[www.youtube.com](http://www.youtube.com)

Cynthia Lin (Youtube)  
[www.cynthialin.com](http://www.cynthialin.com)

Ukulenny (Youtube)  
[www.ukulenny.com](http://www.ukulenny.com)

Ukulele Mike  
[www.youtube.com](http://www.youtube.com)

Craig Chee & Sarah Maisel  
[www.CheeMaisel.com](http://www.CheeMaisel.com)

30 min free lesson monthly  
Uke University 2x/year  
[www.peninsulaukulelegroup](http://www.peninsulaukulelegroup)

## SongBooks:

Jim's Ukulele Songbook  
[www.ozbcoz.com](http://www.ozbcoz.com)

San Jose Ukulele Club  
[www.sanjoseukeclub.org](http://www.sanjoseukeclub.org)





























Bytown Ukulele Group  
[www.bytownukulele.ca](http://www.bytownukulele.ca)

UkeStuff/Video Playalongs  
<https://ukestuff.wordpress.com/video-play-alongs/>

PUGs Music Library  
Peninsula Ukulele Group  
[www.meetup.com/Peninsula-Ukulele-Group](http://www.meetup.com/Peninsula-Ukulele-Group)  
(link at bottom of About Us)

Amelia Plays Ukulele  
<http://ameliaplaysukulele.com>

## Common Ukulele Strums

<b>4 / 4 time</b>					
<b>Basic</b>	1 D	2 D <small>(mute/chuck)</small>	3 D	4 D <small>(mute/chuck)</small>	
<b>Basic down-up</b>	 1 & D U	 2 & D U <small>(mute/chuck D)</small>	 3 & D U	 4 & D U <small>(mute/chuck D)</small>	
<b>"Milk and Cereal"</b>	 1 D	 2 D <small>(mute/chuck)</small>	 3 & D U	 4 D <small>(mute/chuck)</small>	
<b>"Strawberry Coconut"</b>	 1 D	 2 & D U <small>(mute/chuck D)</small>	 3 & D U	 4 D <small>(mute/chuck D)</small>	
<b>Island strum</b> Jamaica Farewell, Island Style, etc.	 1 D	 2 & D U <small>(mute/chuck D)</small>	 (3) & U	 4 D <small>(mute/chuck)</small>	
<b>3/4 time</b>		 			
Edelweiss, Amazing grace, etc	1 D (or pluck)	2 (& D (U)	3 D <small>(mute/chuck)</small>		
<b>6/8 time</b>					
Halleluja, House of the Rising Sun, etc.	1 D	2 U	3 D	4 U	5 D



**Uke University**

## **Uke University- Intermediate Weekly 3 class series**

**Prerequisite: Uke University for Beginners or one year of playing experience and knows basic and movable chords, basic strumming, and how to read and play tabs.**

### **Highlights:**

**Percussive techniques and chucking**

**Intermediate strum techniques**

**Playing chords up the neck/alternate chord positions**

**Color chords- what are they and how to use them**

**Circle of Fifths/Transposing a Song to a different Key**

**Scales and Soloing**

# **Congratulations!**

You have graduated from  
Uke University!

Now let's join a Jam Session  
And Have Some Fun!

Welcome to the huge World Wide  
Ukulele Community!

You've won a Free Uke University Kazoo!

